

Case/Tray Lidder
SWF VL 480 Lid-Matic



Key Features

- Forms and seals lids onto filled cases/trays in one continuous motion
- Up to 25 cases/trays per minute
- Allen-Bradley components
- Mechanical simplicity
- Heavy-duty construction
- Compact footprint

Case/Tray Lidded

SWF VL 480 Lid-Matic

Standard Features

- Pressurized hot melt glue unit
- Gravity roller case discharge
- Programmable Logic Controller - control switches easily accessible to operator
- Polycarbonate interlocked guard package

Optional Features

- Multiple case size adjustment features - used for multiple tray sizes
- 2-sided, 4-sided or DST lids
- Case pass-through capability
- Random case height capability
- Quick-change features
- Large capacity magazine

Specifications	
Electrical Requirements	
Electrical Service	460 volts, 3 phase, 60 Hz
Air Requirements	
15 CFM @ 80 psi	

Typical Lidding Configurations:

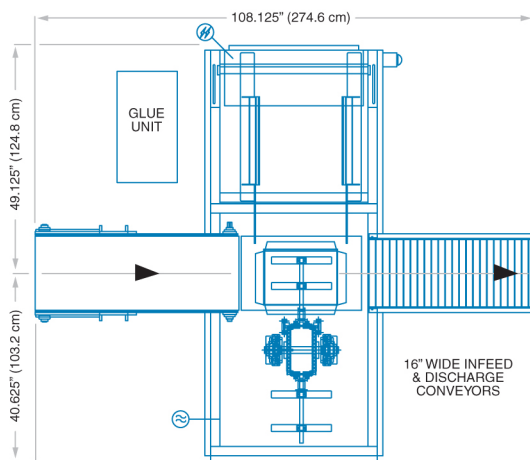
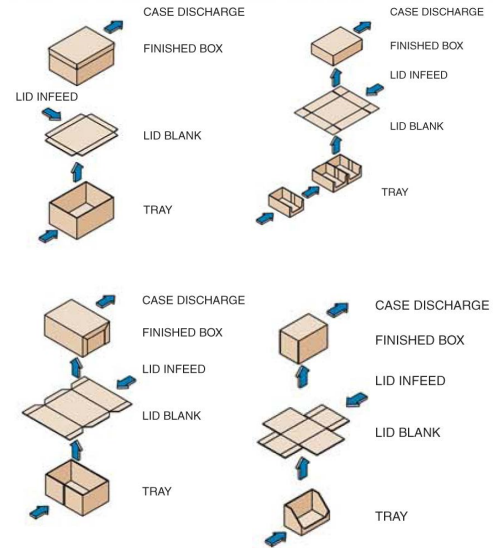

Foot print VL 480

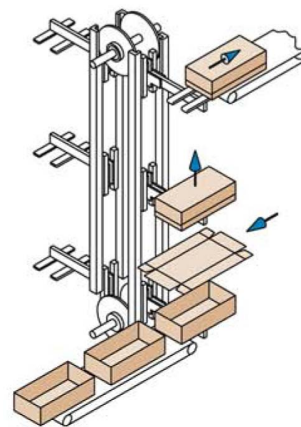

Operating sequence

All sales are subject to our prevailing terms and conditions. Illustrations and specifications are subject to change without notice. Machines shown without guards are for illustrative purposes only. Guards are supplied and must be in place before operation.



Thiele Technologies

315 27TH AVENUE NORTHEAST | MINNEAPOLIS, MN 55418 USA
 +1 (612) 782-1200 | WWW.THIELETECH.COM | SALES@THIELETECH.COM